

Catifa 53

Design by Lievore Altherr Molina, 2001

Art. 0219

Chair with chromed or powdercoated steel fixed trestle base mounted on self-braking castors. Matt polypropylene shell available in single-colour or upholstered in hard leather grade 1 (CT) or hard leather grade 2 (CU). Polypropylene and steel armrests, are available upon request.



Dimensions *

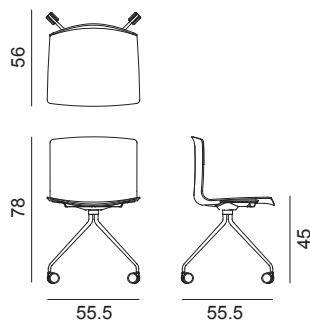

* File CAD 2D - 3D available for download at www.arper.com

Frame Base

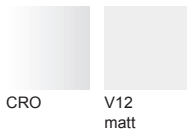

Shell

Polypropylene



PO
Polypropylene
one color

Hard leather Grade 1 and Grade 2



CT CU

arper

F +39 0422 791800

T +39 0422 7918

www.arper.com

Catifa 53

Design by Lievore Altherr Molina, 2001

Accessories:



Cushion Art. 0231



Armrests BV



Armrests CV - pad (only for PO)

SHIPMENT DETAILS

Art.0219

1 pz = 2  - kg 11,3/ m² 0,28

4 pz = 2  - kg 35,04/ m² 0,38

RESISTANCE TEST

- EN 1728:2000 - EN 15373:2007 6.2.1
- EN 1728:2000 - EN 15373:2007 6.7
- EN 1022:05

- EN 1728:2000 - EN 15373:2007 6.2.2
- EN 1728:2000 - EN 15373:2007 6.8

FIRE RETARDANT TEST

BS5852/90 Sez.5 cigarette match polypropylene • BS5852 Sch. 5 Part 1 CT CU

ENVIRONMENTAL CERTIFICATIONS



arper

F +39 0422 791800

T +39 0422 7918

www.arper.com

Catifa 53

Design by Lievore Altherr Molina, 2001

Art. 0221

Chair with chromed or powdercoated steel fixed trestle base, mounted on self-breaking castors. The shell is upholstered in leather, faux leather, fabric or customer's material. Polypropylene armrests, also upholstered, are available upon request. Steel armrests, also upholstered, are available upon request.



Dimensions *

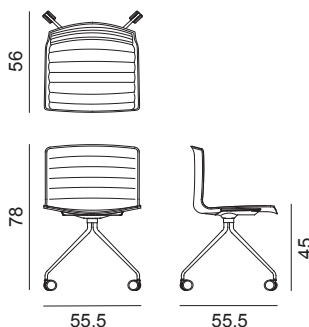

* File CAD 2D - 3D available for download at www.arper.com

Frame Base



Shell

Carded In

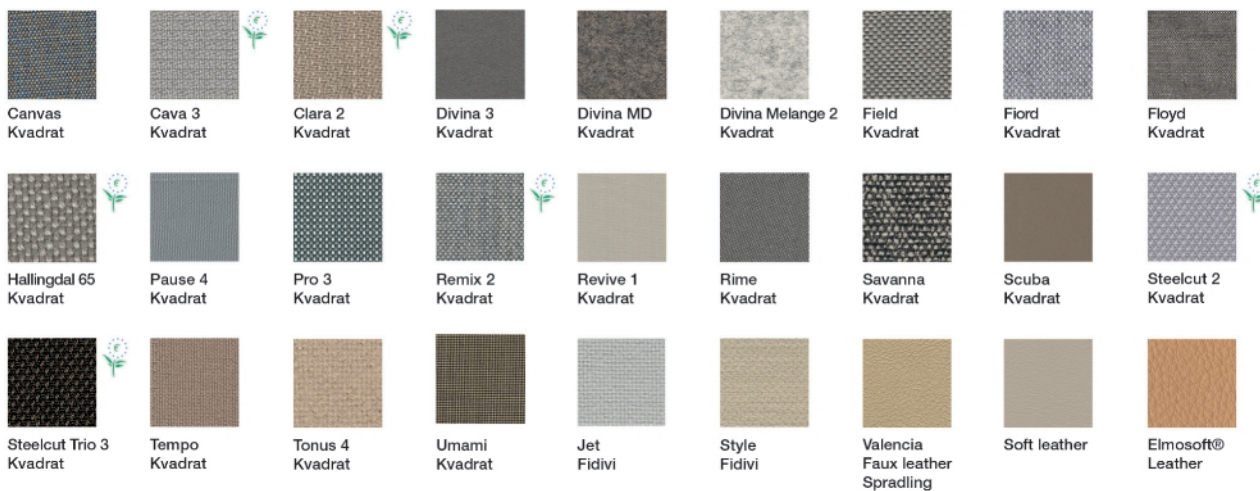

Graded In

kvadrat

camira



DESIGN
TEX



Gabriel



svensson

maharam

Serge Ferrari

Catifa 53

Design by Lievore Altherr Molina, 2001



Armrests BV



Armrests CI - only pad

SHIPMENT DETAILS

Art.0221

1 pz = 2 - kg 12,3/ m³ 0,29

4 pz = 2 - kg 39,44/ m³ 0,42

TECHNICAL SPECIFICATIONS

Art.0221

COL requirement m² 1.78

H 140 cm. COM Meterage ml 1.21

Line detail stitching.

RESISTANCE TEST

- EN 1728:2000 - EN 15373:2007 6.2.1
- EN 1728:2000 - EN 15373:2007 6.7
- EN 1022:05

- EN 1728:2000 - EN 15373:2007 6.2.2
- EN 1728:2000 - EN 15373:2007 6.8

FIRE RETARDANT TEST

BS5852 i.s. 5 Cava 3 Soft leather Elmosoft Hallingdal 65 Pro 3 Tonus 4 • Classe 1IM Cava 3 Divina MD Divina Melange 2 Divina 3 Hallingdal 65 Pro 3 Soft leather Tonus 4 Faux leather Valencia • California TB117-2013 Cava 3 Clara Canvas Divina MD Divina Melange 2 Divina 3 Soft leather Elmosoft Field Hallingdal 65 Jet Jumper 3 Pro 3 Soft leather Pause 4 Remix 2 Savanna Steelcut 2 Scuba Steelcut Trio 2 Steelcut Trio 3 Sunniva Sunniva 2 Tonus 4 Tempo Faux leather Valencia • BS5852 Sch. 4 Part 1 Cava 3 Divina MD Divina Melange 2 Divina 3 Soft leather Elmosoft Hallingdal 65 Pro 3 Tonus 4 Faux leather Valencia • BS5852 Sch. 5 Part 1 Cava 3 Clara Canvas Divina MD Divina Melange 2 Divina 3 Soft leather Elmosoft Hallingdal 65 Soft leather Remix 2 Savanna Steelcut 2 Steelcut Trio 2 Steelcut Trio 3 Tonus 4 Faux leather Valencia • EN 1021 - 1 Divina MD Divina Melange 2 Divina 3 Soft leather Elmosoft Field Hallingdal 65 Pro 3 Soft leather • EN 1021 - 2 Divina MD Divina Melange 2 Divina 3 Soft leather Elmosoft Field Hallingdal 65 Pro 3 Soft leather

ENVIRONMENTAL CERTIFICATIONS



arper

F +39 0422 791800

T +39 0422 7918

www.arper.com

Catifa 53

Design by Lievore Altherr Molina, 2001

Art. 0245

Chair with chromed or powdercoated steel fixed trestle base, mounted on self-braking castors. The wood shell is available in four finishes (natural oak, bleached oak, wengé, teak). Steel armrests are available upon request.



Dimensions *

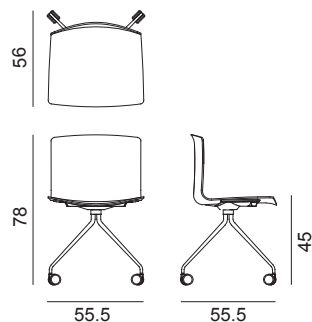

* File CAD 2D - 3D available for download at www.arper.com

Frame Base

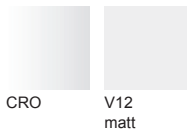

Shell

Wood



arper

F +39 0422 791800

T +39 0422 7918

www.arper.com

Catifa 53

Design by Lievore Altherr Molina, 2001

Accessories:

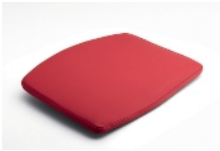

Cushion Art. 0231



Armrests BV

SHIPMENT DETAILS

Art.0245

1 pz = 2  - kg 11,82/ m² 0,28

4 pz = 2  - kg 34,44/ m² 0,38

RESISTANCE TEST

ENVIRONMENTAL CERTIFICATIONS



TECHNICAL SPECIFICATIONS

FIRE RETARDANT TEST

BS5852/90 Sez.5 cigarette match LG • Classe 1 LG

arper

F +39 0422 791800

T +39 0422 7918

www.arper.com

Catifa 53

Design by Lievore Altherr Molina, 2001

Art. 2044

Chair with chromed or powdercoated steel fixed trestle base, mounted on self-braking castors. Matt polypropylene shell with leather, faux leather, fabric or customer's material upholstery applied to the seat surface. Steel armrests, also upholstered, are available upon request.



Dimensions *

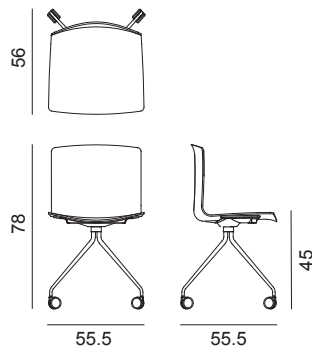

* File CAD 2D - 3D available for download at www.arper.com

Frame Base



CRO

V12
matt

Shell

Polypropylene



PO
Polypropylene
one color

Carded In



Canvas
Kvadrat



Cava 3
Kvadrat



Clara 2
Kvadrat



Divina 3
Kvadrat



Divina MD
Kvadrat



Divina Melange 2
Kvadrat



Field
Kvadrat



Fiord
Kvadrat



Floyd
Kvadrat



Hallingdal 65
Kvadrat



Pause 4
Kvadrat



Pro 3
Kvadrat



Remix 2
Kvadrat



Revive 1
Kvadrat



Rime
Kvadrat



Savanna
Kvadrat



Scuba
Kvadrat



Steelcut 2
Kvadrat



Steelcut Trio 3
Kvadrat



Tempo
Kvadrat



Tonus 4
Kvadrat



Umami
Kvadrat



Jet
Fidivi



Style
Fidivi



Valencia
Faux leather
Spradling



Soft leather



Elmosoft®
Leather

Graded In

kvadrat

camira



DESIGN
TEX



Gabriel



svensson

maharam

Serge Ferrari

Catifa 53

Design by Lievore Altherr Molina, 2001



Armrests BV



Armrests CI - only pad

SHIPMENT DETAILS

Art.2044

1 pz = 2 - kg 13,8/ m² 0,28

4 pz = 2 - kg 42,7/ m² 0,42

RESISTANCE TEST

- EN 1728:2000 - EN 15373:2007 6.2.1
- EN 1728:2000 - EN 15373:2007 6.2.2
- EN 1728:2000 - EN 15373:2007 6.7
- EN 1728:2000 - EN 15373:2007 6.8
- EN 1022:05

TECHNICAL SPECIFICATIONS

Art.2044

COL requirement m² 0.84

H 140 cm. COM Meterage ml 0.72

FIRE RETARDANT TEST

BS5852 i.s. 5 Cava 3 Soft leather Elmosoft Hallingdal 65 Pro 3 Tonus 4 • Classe 1IM Cava 3 Divina MD Divina Melange 2 Divina 3 Hallingdal 65 Pro 3 Soft leather Tonus 4 Faux leather Valencia • California TB117-2013 Cava 3 Clara Canvas Divina MD Divina Melange 2 Divina 3 Soft leather Elmosoft Field Hallingdal 65 Jet Jumper 3 Pro 3 Soft leather Pause 4 Remix 2 Savanna Steelcut 2 Scuba Steelcut Trio 2 Steelcut Trio 3 Sunniva Sunniva 2 Tonus 4 Tempo Faux leather Valencia • BS5852 Sch. 4 Part 1 Cava 3 Divina MD Divina Melange 2 Divina 3 Soft leather Elmosoft Hallingdal 65 Pro 3 Tonus 4 Faux leather Valencia • BS5852 Sch. 5 Part 1 Cava 3 Clara Canvas Divina MD Divina Melange 2 Divina 3 Soft leather Elmosoft Hallingdal 65 Soft leather Remix 2 Savanna Steelcut 2 Steelcut Trio 2 Steelcut Trio 3 Tonus 4 Faux leather Valencia • EN 1021 - 1 Divina MD Divina Melange 2 Divina 3 Soft leather Elmosoft Field Hallingdal 65 Pro 3 Soft leather • EN 1021 - 2 Divina MD Divina Melange 2 Divina 3 Soft leather Elmosoft Field Hallingdal 65 Pro 3 Soft leather

ENVIRONMENTAL CERTIFICATIONS



arper

F +39 0422 791800

T +39 0422 7918

www.arper.com

Catifa 53

Design by Lievore Altherr Molina, 2001

Art. 2055

Chair with polished or powdercoated aluminium fixed trestle base mounted on self-braking castors. Matt polypropylene shell available in single-colour or upholstered in hard leather grade one or hard leather grade two. Polypropylene and steel armrests, are available upon request.



Dimensions *

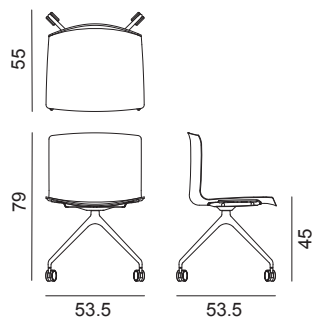

* File CAD 2D - 3D available for download at www.arper.com

Frame Base

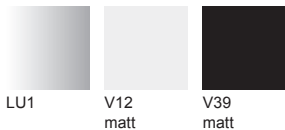

LU1

V12
matt

V39
matt

Shell

Polypropylene



PO
Polypropylene
one color

Hard leather Grade 1 and Grade 2



CT

CU

arper

F +39 0422 791800

T +39 0422 7918

www.arper.com

Catifa 53

Design by Lievore Altherr Molina, 2001

Accessories:

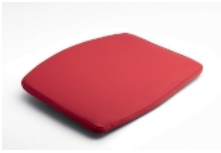

Cushion Art. 0231



Armrests BV



Armrests CV - pad (only for PO)

SHIPMENT DETAILS

Art.2055

1 pz = 2  - kg 10,8/ m² 0,28

4 pz = 2  - kg 32,2/ m² 0,38

RESISTANCE TEST

FIRE RETARDANT TEST

BS5852/90 Sez.5 cigarette match polypropylene • BS5852 Sch. 5 Part 1
CT CU

ENVIRONMENTAL CERTIFICATIONS



arper

F +39 0422 791800

T +39 0422 7918

www.arper.com

Catifa 53

Design by Lievore Altherr Molina, 2001

Art. 2057

Chair with polished or powdercoated aluminium fixed trestle base, mounted on self-braking castors. Matt polypropylene shell with leather, faux leather, fabric or customer's material upholstery applied to the seat surface. Steel armrests, also upholstered, are available upon request.



Dimensions *

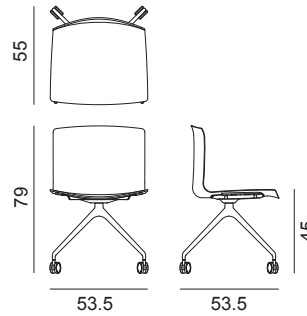

* File CAD 2D - 3D available for download at www.arper.com

Frame Base



Shell

Polypropylene



PO
Polypropylene
one color

Carded In



Graded In

kvadrat

camira



DESIGN
TEX



Gabriel



svensson

maharam

Serge Ferrari

Catifa 53

Design by Lievore Altherr Molina, 2001



Armrests BV



Armrests CI - only pad

SHIPMENT DETAILS

Art.2057

1 pz = 2  - kg 12,7/ m² 0,29

4 pz = 2  - kg 40,2/ m² 0,42

TECHNICAL SPECIFICATIONS

Art.2057

COL requirement m² 0.84

H 140 cm. COM Meterage ml 0.72

RESISTANCE TEST

FIRE RETARDANT TEST

BS5852 i.s. 5 Cava 3 Soft leather Elmosoft Hallingdal 65 Pro 3 Tonus 4 • Classe 11M Cava 3 Divina MD Divina Melange 2 Divina 3 Hallingdal 65 Pro 3 Soft leather Tonus 4 Faux leather Valencia • California TB117-2013 Cava 3 Clara Canvas Divina MD Divina Melange 2 Divina 3 Soft leather Elmosoft Field Hallingdal 65 Jet Jumper 3 Pro 3 Soft leather Pause 4 Remix 2 Savanna Steelcut 2 Scuba Steelcut Trio 2 Steelcut Trio 3 Sunniva Sunniva 2 Tonus 4 Tempo Faux leather Valencia • BS5852 Sch. 4 Part 1 Cava 3 Divina MD Divina Melange 2 Divina 3 Soft leather Elmosoft Hallingdal 65 Pro 3 Tonus 4 Faux leather Valencia • BS5852 Sch. 5 Part 1 Cava 3 Clara Canvas Divina MD Divina Melange 2 Divina 3 Soft leather Elmosoft Hallingdal 65 Soft leather Remix 2 Savanna Steelcut 2 Steelcut Trio 2 Steelcut Trio 3 Tonus 4 Faux leather Valencia • EN 1021 - 1 Divina MD Divina Melange 2 Divina 3 Soft leather Elmosoft Field Hallingdal 65 Pro 3 Soft leather • EN 1021 - 2 Divina MD Divina Melange 2 Divina 3 Soft leather Elmosoft Field Hallingdal 65 Pro 3 Soft leather

ENVIRONMENTAL CERTIFICATIONS



arper

F +39 0422 791800

T +39 0422 7918

www.arper.com

Catifa 53

Design by Lievore Altherr Molina, 2001

Art. 2061

Chair with polished or powdercoated aluminium fixed trestle base, mounted on self-braking castors. The shell is upholstered in leather, faux leather, fabric or customer's material. Steel armrests, also upholstered, are available upon request.



Dimensions *

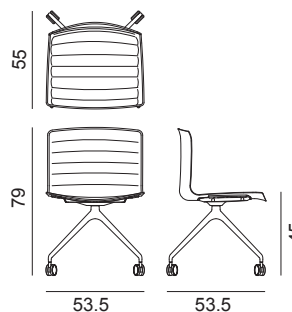

* File CAD 2D - 3D available for download at www.arper.com

Frame Base



Shell

Carded In

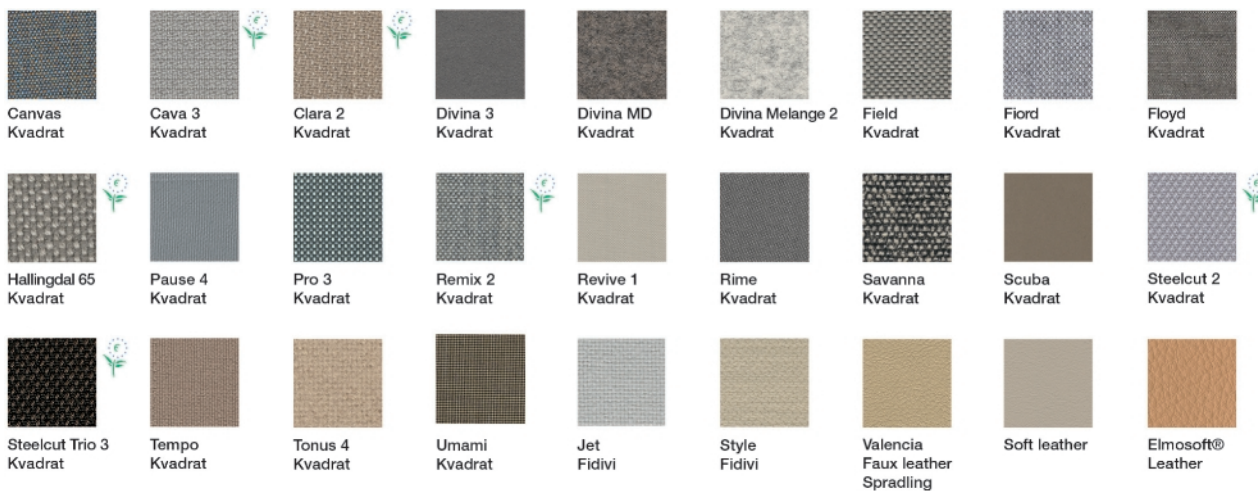

Graded In

kvadrat

camira



DESIGN
TEX



Gabriel



svensson

maharam

Serge Ferrari

Catifa 53

Design by Lievore Altherr Molina, 2001



Armrests BV



Armrests CI - only pad

SHIPMENT DETAILS

Art.2061

1 pz = 2  - kg 11,8/ m² 0,29

4 pz = 2  - kg 36,6/ m² 0,42

TECHNICAL SPECIFICATIONS

Art.2061

COL requirement m² 1.78

H 140 cm. COM Meterage ml 1.2.

RESISTANCE TEST

FIRE RETARDANT TEST

BS5852 i.s. 5 Cava 3 Soft leather Elmosoft Hallingdal 65 Pro 3 Tonus 4 • Classe 11M Cava 3 Divina MD Divina Melange 2 Divina 3 Hallingdal 65 Pro 3 Soft leather Tonus 4 Faux leather Valencia • California TB117-2013 Cava 3 Clara Canvas Divina MD Divina Melange 2 Divina 3 Soft leather Elmosoft Field Hallingdal 65 Jet Jumper 3 Pro 3 Soft leather Pause 4 Remix 2 Savanna Steelcut 2 Scuba Steelcut Trio 2 Steelcut Trio 3 Sunniva Sunniva 2 Tonus 4 Tempo Faux leather Valencia • BS5852 Sch. 4 Part 1 Cava 3 Divina MD Divina Melange 2 Divina 3 Soft leather Elmosoft Hallingdal 65 Pro 3 Tonus 4 Faux leather Valencia • BS5852 Sch. 5 Part 1 Cava 3 Clara Canvas Divina MD Divina Melange 2 Divina 3 Soft leather Elmosoft Hallingdal 65 Soft leather Remix 2 Savanna Steelcut 2 Steelcut Trio 2 Steelcut Trio 3 Tonus 4 Faux leather Valencia • EN 1021 - 1 Divina MD Divina Melange 2 Divina 3 Soft leather Elmosoft Field Hallingdal 65 Pro 3 Soft leather • EN 1021 - 2 Divina MD Divina Melange 2 Divina 3 Soft leather Elmosoft Field Hallingdal 65 Pro 3 Soft leather

ENVIRONMENTAL CERTIFICATIONS



arper

F +39 0422 791800

T +39 0422 7918

www.arper.com

Catifa 53

Design by Lievore Altherr Molina, 2001

Art. 2063

Chair with polished or powdercoated aluminium fixed trestle base, mounted on self-braking castors. The wood shell is available in four colours (natural oak, bleached oak, wengé and teak). Steel armrests are available upon request.



Dimensions *

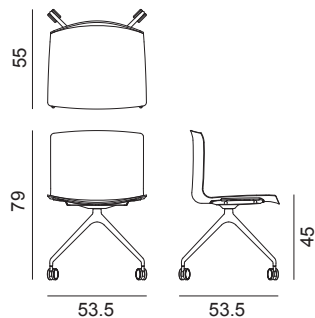

* File CAD 2D - 3D available for download at www.arper.com

Frame Base

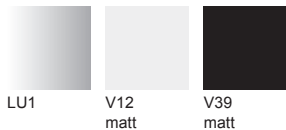

Shell

Wood



arper

F +39 0422 791800

T +39 0422 7918

www.arper.com

Catifa 53

Design by Lievore Altherr Molina, 2001

Accessories:



Cushion Art. 0231



Armrests BV

SHIPMENT DETAILS

Art.2063

1 pz = 2  - kg 10,72/ m² 0,28

4 pz = 2  - kg 31,6/ m² 0,38

RESISTANCE TEST

ENVIRONMENTAL CERTIFICATIONS



TECHNICAL SPECIFICATIONS

FIRE RETARDANT TEST

BS5852/90 Sez.5 cigarette match LG • Classe 1 LG

arper

F +39 0422 791800

T +39 0422 7918

www.arper.com

Catifa 53

Design by Lievore Altherr Molina, 2001

Art. 2099

Chair with chromed or powdercoated steel fixed trestle base mounted on self-breaking castors. Double-curved wood shell available in four finishes (natural oak, bleached oak, wengé, teak) with front upholstery in leather, faux leather, fabric or customer's material. Steel armrests, also upholstered, are available upon request.



Dimensions *

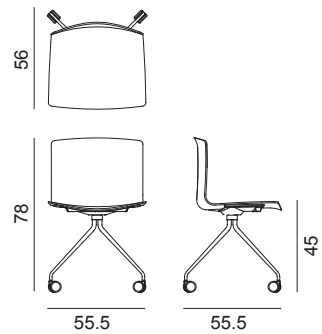

* File CAD 2D - 3D available for download at www.arper.com

Frame Base



Shell

Wood

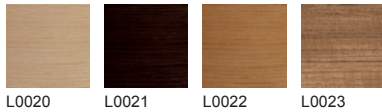

Carded In

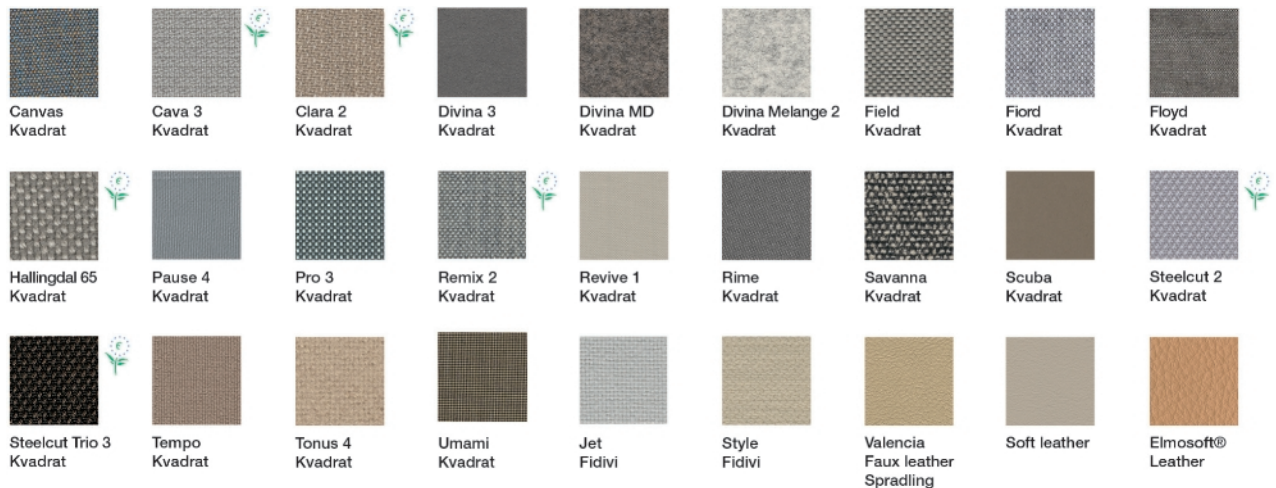

Graded In

kvadrat

camira



DESIGN
TEX



Gabriel



svensson

maharam

Serge Ferrari

Catifa 53

Design by Lievore Altherr Molina, 2001



Armrests BV



Armrests CI - only pad

SHIPMENT DETAILS

Art.2099

1 pz = 2 - kg 13,8/ m² 0,28

4 pz = 2 - kg 42,7/ m² 0,42

TECHNICAL SPECIFICATIONS

Art.2099

COL requirement m² 0.84

H 140 cm. COM Meterage ml 0.72

RESISTANCE TEST

FIRE RETARDANT TEST

BS5852 i.s. 5 Cava 3 Soft leather Elmosoft Hallingdal 65 Pro 3 Tonus 4 • Classe 1IM Cava 3 Divina MD Divina Melange 2 Divina 3 Hallingdal 65 Pro 3 Soft leather Tonus 4 Faux leather Valencia • California TB117-2013 Cava 3 Clara Canvas Divina MD Divina Melange 2 Divina 3 Soft leather Elmosoft Field Hallingdal 65 Jet Jumper 3 Pro 3 Soft leather Pause 4 Remix 2 Savanna Steelcut 2 Scuba Steelcut Trio 2 Steelcut Trio 3 Sunniva Sunniva 2 Tonus 4 Tempo Faux leather Valencia • BS5852 Sch. 4 Part 1 Cava 3 Divina MD Divina Melange 2 Divina 3 Soft leather Elmosoft Hallingdal 65 Pro 3 Tonus 4 Faux leather Valencia • BS5852 Sch. 5 Part 1 Cava 3 Clara Canvas Divina MD Divina Melange 2 Divina 3 Soft leather Elmosoft Hallingdal 65 Soft leather Remix 2 Savanna Steelcut 2 Steelcut Trio 2 Steelcut Trio 3 Tonus 4 Faux leather Valencia • EN 1021 - 1 Divina MD Divina Melange 2 Divina 3 Soft leather Elmosoft Field Hallingdal 65 Pro 3 Soft leather • EN 1021 - 2 Divina MD Divina Melange 2 Divina 3 Soft leather Elmosoft Field Hallingdal 65 Pro 3 Soft leather

ENVIRONMENTAL CERTIFICATIONS



arper

F +39 0422 791800

T +39 0422 7918

www.arper.com

Catifa 53

Design by Lievore Altherr Molina, 2001

Art. 3103

Chair with polished or powdercoated aluminium fixed trestle base mounted on self-braking castors. Double curved wood shell available in four finishes (natural oak, bleached oak, wengé, teak) with front face upholstered in leather, faux leather, fabric or customer's material. Steel armrests, also upholstered, are available upon request.



Dimensions *

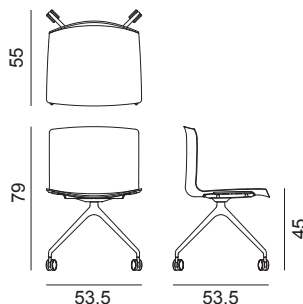

* File CAD 2D - 3D available for download at www.arper.com

Frame Base



Shell

Wood



Carded In

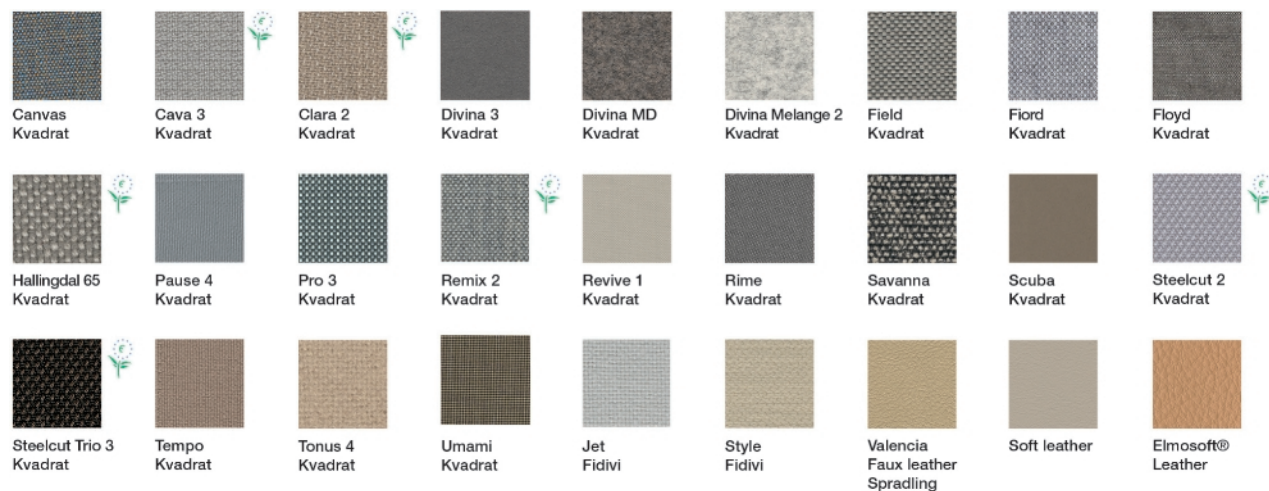

Graded In

kvadrat

camira



DESIGN
TEX



Gabriel



svensson

maharam

Serge Ferrari

Catifa 53

Design by Lievore Altherr Molina, 2001



Armrests BV



Armrests CI - only pad

SHIPMENT DETAILS

Art.3103

1 pz = 2  - kg 12,7/ m² 0,29

4 pz = 2  - kg 40,2/ m² 0,42

TECHNICAL SPECIFICATIONS

Art.3103

COL requirement m² 0.84

H 140 cm. COM Meterage ml 0.72

RESISTANCE TEST

FIRE RETARDANT TEST

BS5852 i.s. 5 Cava 3 Soft leather Elmosoft Hallingdal 65 Pro 3 Tonus 4 • Classe 11M Cava 3 Divina MD Divina Melange 2 Divina 3 Hallingdal 65 Pro 3 Soft leather Tonus 4 Faux leather Valencia • California TB117-2013 Cava 3 Clara Canvas Divina MD Divina Melange 2 Divina 3 Soft leather Elmosoft Field Hallingdal 65 Jet Jumper 3 Pro 3 Soft leather Pause 4 Remix 2 Savanna Steelcut 2 Scuba Steelcut Trio 2 Steelcut Trio 3 Sunniva Sunniva 2 Tonus 4 Tempo Faux leather Valencia • BS5852 Sch. 4 Part 1 Cava 3 Divina MD Divina Melange 2 Divina 3 Soft leather Elmosoft Hallingdal 65 Pro 3 Tonus 4 Faux leather Valencia • BS5852 Sch. 5 Part 1 Cava 3 Clara Canvas Divina MD Divina Melange 2 Divina 3 Soft leather Elmosoft Hallingdal 65 Soft leather Remix 2 Savanna Steelcut 2 Steelcut Trio 2 Steelcut Trio 3 Tonus 4 Faux leather Valencia • EN 1021 - 1 Divina MD Divina Melange 2 Divina 3 Soft leather Elmosoft Field Hallingdal 65 Pro 3 Soft leather • EN 1021 - 2 Divina MD Divina Melange 2 Divina 3 Soft leather Elmosoft Field Hallingdal 65 Pro 3 Soft leather

ENVIRONMENTAL CERTIFICATIONS



arper

F +39 0422 791800

T +39 0422 7918

www.arper.com

Catifa 53

Design by Lievore Altherr Molina, 2013

Art. 3124

Chair with chromed or powdercoated steel fixed trestle base, mounted on self-breaking castors. The white polypropylene shell is upholstered with a removable non-washable cover in leather, faux leather, fabric or customer's own material. The chair is provided already fitted with the cover. Polypropylene armrests, also upholstered, are available upon request. Steel are also upholstered, are available upon request.



Dimensions *

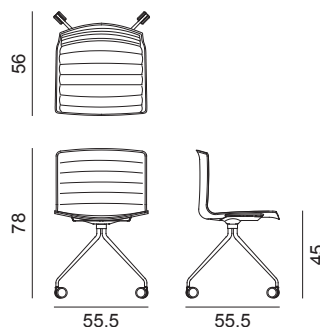

* File CAD 2D - 3D available for download at www.arper.com

Frame Base



Shell

Carded In

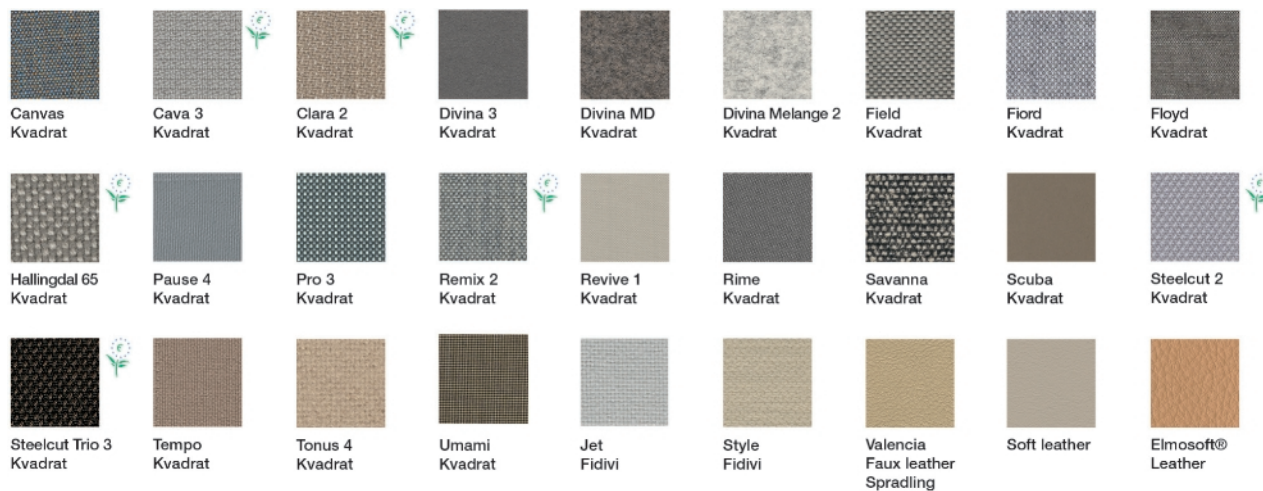

Graded In



arper

F +39 0422 791800

T +39 0422 7918

www.arper.com

Catifa 53

Design by Lievore Altherr Molina, 2013



Armrests BV



Armrests CI - only pad

SHIPMENT DETAILS

Art.3124

1 pz = 2  - kg 12,3/ m² 0,29

4 pz = 2  - kg 39,44/ m² 0,42

TECHNICAL SPECIFICATIONS

Art.3124

COL requirement m² 2,09

H 140 cm. COM Meterage ml 1,23

The cover stitching comes in the same color as the upholstery. Stitching on cover 1 and 3 comes in white or black, to customer's choice.

RESISTANCE TEST

- EN 1728:2000 - EN 15373:2007 6.2.1
- EN 1728:2000 - EN 15373:2007 6.7
- EN 1022:05

- EN 1728:2000 - EN 15373:2007 6.2.2
- EN 1728:2000 - EN 15373:2007 6.8

FIRE RETARDANT TEST

BS5852 i.s. 5 Cava 3 Soft leather Elmosoft Hallingdal 65 Pro 3 Tonus 4 • Classe 1IM Cava 3 Divina MD Divina Melange 2 Divina 3 Hallingdal 65 Pro 3 Soft leather Tonus 4 Faux leather Valencia • California TB117-2013 Cava 3 Clara Canvas Divina MD Divina Melange 2 Divina 3 Soft leather Elmosoft Field Hallingdal 65 Jet Jumper 3 Pro 3 Soft leather Pause 4 Remix 2 Savanna Steelcut 2 Scuba Steelcut Trio 2 Steelcut Trio 3 Sunniva Sunniva 2 Tonus 4 Tempo Faux leather Valencia • BS5852 Sch. 4 Part 1 Cava 3 Divina MD Divina Melange 2 Divina 3 Soft leather Elmosoft Hallingdal 65 Pro 3 Tonus 4 Faux leather Valencia • BS5852 Sch. 5 Part 1 Cava 3 Clara Canvas Divina MD Divina Melange 2 Divina 3 Soft leather Elmosoft Hallingdal 65 Soft leather Remix 2 Savanna Steelcut 2 Steelcut Trio 2 Steelcut Trio 3 Tonus 4 Faux leather Valencia • EN 1021 - 1 Divina MD Divina Melange 2 Divina 3 Soft leather Elmosoft Field Hallingdal 65 Pro 3 Soft leather • EN 1021 - 2 Divina MD Divina Melange 2 Divina 3 Soft leather Elmosoft Field Hallingdal 65 Pro 3 Soft leather

ENVIRONMENTAL CERTIFICATIONS



arper

F +39 0422 791800

T +39 0422 7918

www.arper.com

Catifa 53

Design by Lievore Altherr Molina, 2013

Art. 3126

Chair with polished or powdercoated aluminium fixed trestle base, mounted on self-braking castors. The white polypropylene shell is upholstered with a removable non-washable cover in leather, faux leather, fabric or customer's own material. The chair is provided already fitted with the cover. Steel armrests, also upholstered, are available upon request.



Dimensions *

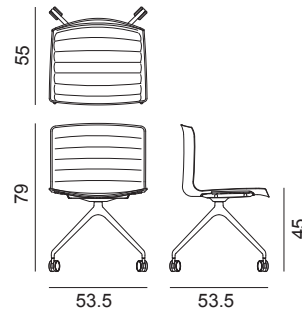

* File CAD 2D - 3D available for download at www.arper.com

Frame Base



arper

Shell

Carded In

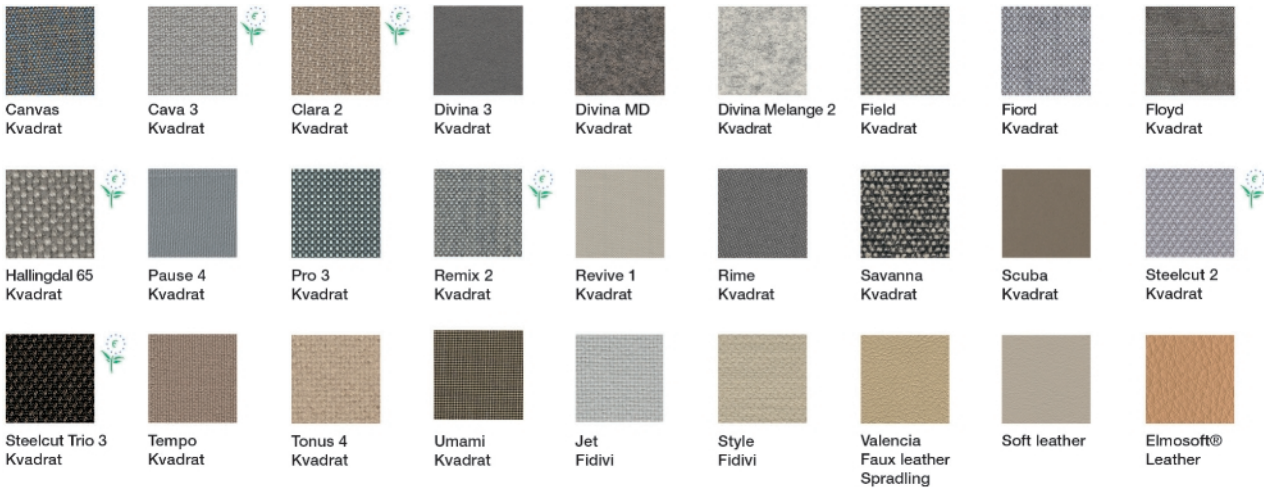

Graded In

kvadrat

camira



DESIGN
TEX



Gabriel



svensson

maharam

Serge Ferrari

Catifa 53

Design by Lievore Altherr Molina, 2013



Armrests BV



Armrests CI - only pad

SHIPMENT DETAILS

Art.3126

1 pz = 2  - kg 11,8/ m² 0,29

4 pz = 2  - kg 36,6/ m² 0,42

TECHNICAL SPECIFICATIONS

Art.3126

COL requirement m² 2,09

H 140 cm. COM Meterage ml 1,23

The cover stitching comes in the same color as the upholstery. Stitching on cover 1 and 3 comes in white or black, to customer's choice.

RESISTANCE TEST

FIRE RETARDANT TEST

BS5852 i.s. 5 Cava 3 Soft leather Elmosoft Hallingdal 65 Pro 3 Tonus 4 • Classe 1IM Cava 3 Divina MD Divina Melange 2 Divina 3 Hallingdal 65 Pro 3 Soft leather Tonus 4 Faux leather Valencia • California TB117-2013 Cava 3 Clara Canvas Divina MD Divina Melange 2 Divina 3 Soft leather Elmosoft Field Hallingdal 65 Jet Jumper 3 Pro 3 Soft leather Pause 4 Remix 2 Savanna Steelcut 2 Scuba Steelcut Trio 2 Steelcut Trio 3 Sunniva Sunniva 2 Tonus 4 Tempo Faux leather Valencia • BS5852 Sch. 4 Part 1 Cava 3 Divina MD Divina Melange 2 Divina 3 Soft leather Elmosoft Hallingdal 65 Pro 3 Tonus 4 Faux leather Valencia • BS5852 Sch. 5 Part 1 Cava 3 Clara Canvas Divina MD Divina Melange 2 Divina 3 Soft leather Elmosoft Hallingdal 65 Soft leather Remix 2 Savanna Steelcut 2 Steelcut Trio 2 Steelcut Trio 3 Tonus 4 Faux leather Valencia • EN 1021 - 1 Divina MD Divina Melange 2 Divina 3 Soft leather Elmosoft Field Hallingdal 65 Pro 3 Soft leather • EN 1021 - 2 Divina MD Divina Melange 2 Divina 3 Soft leather Elmosoft Field Hallingdal 65 Pro 3 Soft leather

ENVIRONMENTAL CERTIFICATIONS



arper

F +39 0422 791800

T +39 0422 7918

www.arper.com