

Duna 02

Design by Lievore Altherr Molina, 2014

Art. 4207

Armchair with polished or powdercoated aluminium fixed trestle base, mounted on selfbraking castors. Polypropylene shell available in six colors.



Dimensions *

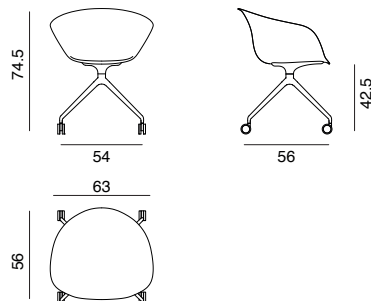

* File CAD 2D - 3D available for download at www.arper.com

Frame Base

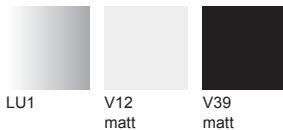

Shell

Polypropylene



arper

F +39 0422 791800

T +39 0422 7918

www.arper.com

Duna 02

Design by Lievore Altherr Molina, 2014

SHIPMENT DETAILS

Art.4207

1 pz = 2  - kg 15,38/ m³ 0,37

4 pz = 2  - kg 46,6/ m³ 0,55

RESISTANCE TEST

- EN 1728:2012 - EN 16139:2013 6.10
- EN 1728:2012 - EN 16139:2013 6.17
- EN 1728:2012 - EN 16139:2013 6.20
- EN 1728:2012 - EN 16139:2013 6.25
- EN 1728:2012 - EN 16139:2013 6.4
- EN 1022:05

- EN 1728:2012 - EN 16139:2013 6.11
- EN 1728:2012 - EN 16139:2013 6.18
- EN 1728:2012 - EN 16139:2013 6.24
- EN 1728:2012 - EN 16139:2013 6.26
- EN 1728:2012 - EN 16139:2013 6.5

FIRE RETARDANT TEST

ENVIRONMENTAL CERTIFICATIONS



arper

F +39 0422 791800

T +39 0422 7918

www.arper.com

Duna 02

Design by Lievore Altherr Molina, 2014

Art. 4217

Armchair with polished or powdercoated aluminium fixed trestle base, mounted on selfbraking castors. Polypropylene shell available in six colors, with front upholstery in leather, faux leather, fabric or customer's own material front upholstery.



Dimensions *

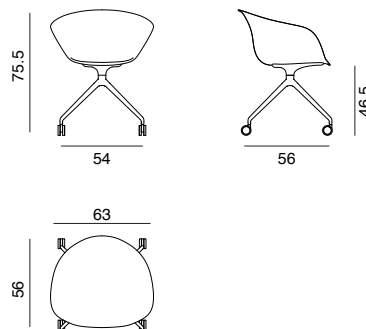

* File CAD 2D - 3D available for download at www.arper.com

Frame Base



Shell

Polypropylene

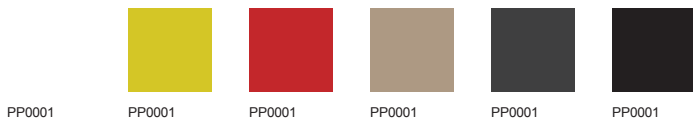

Carded In

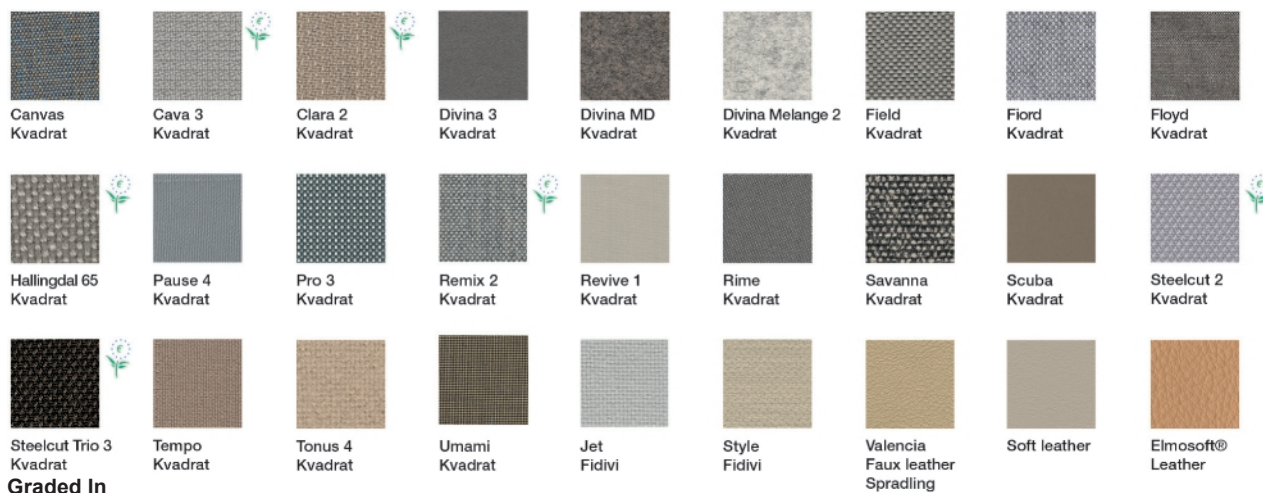

Graded In

kvadrat

camira



DESIGN
TEX



Gabriel



svensson

maharam

Serge Ferrari

Duna 02

Design by Lievore Altherr Molina, 2014

SHIPMENT DETAILS

Art.4217

1 pz = 2  - kg 15,38/ m³ 0,37

4 pz = 2  - kg 46,6/ m³ 0,55

TECHNICAL SPECIFICATIONS

Art.4217

COL requirement m² 1.44

H 140 cm. COM Meterage ml 1.05

RESISTANCE TEST

- EN 1728:2012 - EN 16139:2013 6.10
- EN 1728:2012 - EN 16139:2013 6.17
- EN 1728:2012 - EN 16139:2013 6.20
- EN 1728:2012 - EN 16139:2013 6.25
- EN 1728:2012 - EN 16139:2013 6. 4
- EN 1022:05

- EN 1728:2012 - EN 16139:2013 6.11
- EN 1728:2012 - EN 16139:2013 6.18
- EN 1728:2012 - EN 16139:2013 6.24
- EN 1728:2012 - EN 16139:2013 6.26
- EN 1728:2012 - EN 16139:2013 6. 5

FIRE RETARDANT TEST

Classe 1M Cava 3 Field

ENVIRONMENTAL CERTIFICATIONS



arper

F +39 0422 791800

T +39 0422 7918

www.arper.com

Duna 02

Design by Lievore Altherr Molina, 2014

Art. 4227

Armchair with polished or powdercoated aluminium fixed trestle base, mounted on selfbraking castors. Polypropylene shell available in six colors, with cushion in leather, faux leather, fabric or customer's own material applied on the seat surface.



Dimensions *

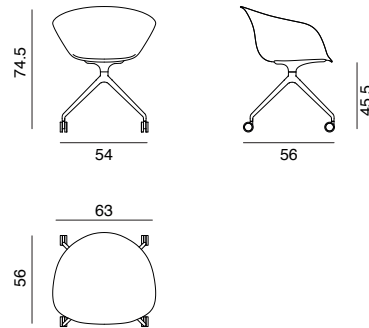

* File CAD 2D - 3D available for download at www.arper.com

Frame Base

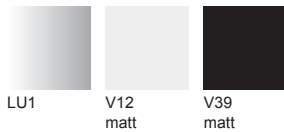

Shell

Polypropylene



Carded In

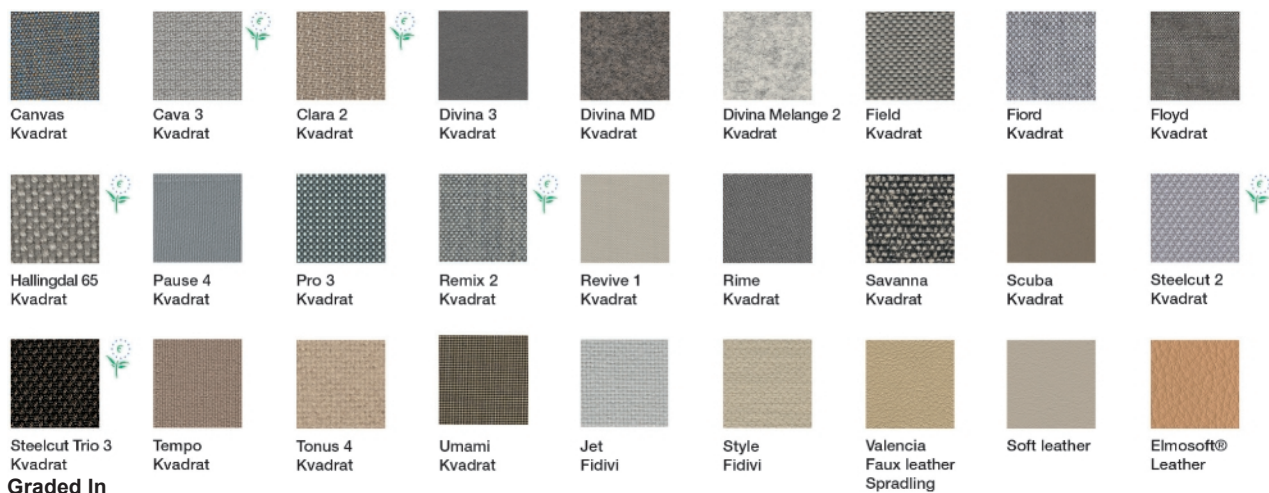

Graded In

kvadrat

camira



DESIGN
TEX



Gabriel



svensson

maharam

Serge Ferrari

Duna 02

Design by Lievore Altherr Molina, 2014

SHIPMENT DETAILS

Art.4227

1 pz = 2  - kg 15,38/ m³ 0,37

4 pz = 2  - kg 46,6/ m³ 0,55

TECHNICAL SPECIFICATIONS

Art.4227

COL requirement m² 0.56

H 140 cm. COM Meterage ml 0.55

RESISTANCE TEST

- EN 1728:2012 - EN 16139:2013 6.10
- EN 1728:2012 - EN 16139:2013 6.17
- EN 1728:2012 - EN 16139:2013 6.20
- EN 1728:2012 - EN 16139:2013 6.25
- EN 1728:2012 - EN 16139:2013 6. 4
- EN 1022:05

- EN 1728:2012 - EN 16139:2013 6.11
- EN 1728:2012 - EN 16139:2013 6.18
- EN 1728:2012 - EN 16139:2013 6.24
- EN 1728:2012 - EN 16139:2013 6.26
- EN 1728:2012 - EN 16139:2013 6. 5

FIRE RETARDANT TEST

Classe 1M Cava 3 Field

ENVIRONMENTAL CERTIFICATIONS



arper

F +39 0422 791800

T +39 0422 7918

www.arper.com

Duna 02

Design by Lievore Altherr Molina, 2014

Art. 4237

Armchair with polished or powdercoated aluminium fixed trestle base, mounted on selfbraking castors. Shell fully upholstered in leather, faux leather, fabric or customer's own material.



Dimensions *

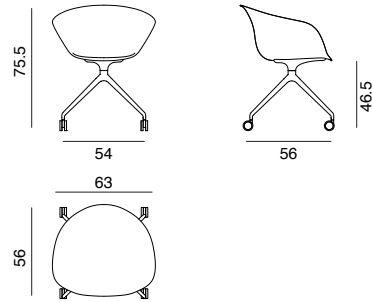

* File CAD 2D - 3D available for download at www.arper.com

Frame Base



Shell

Carded In

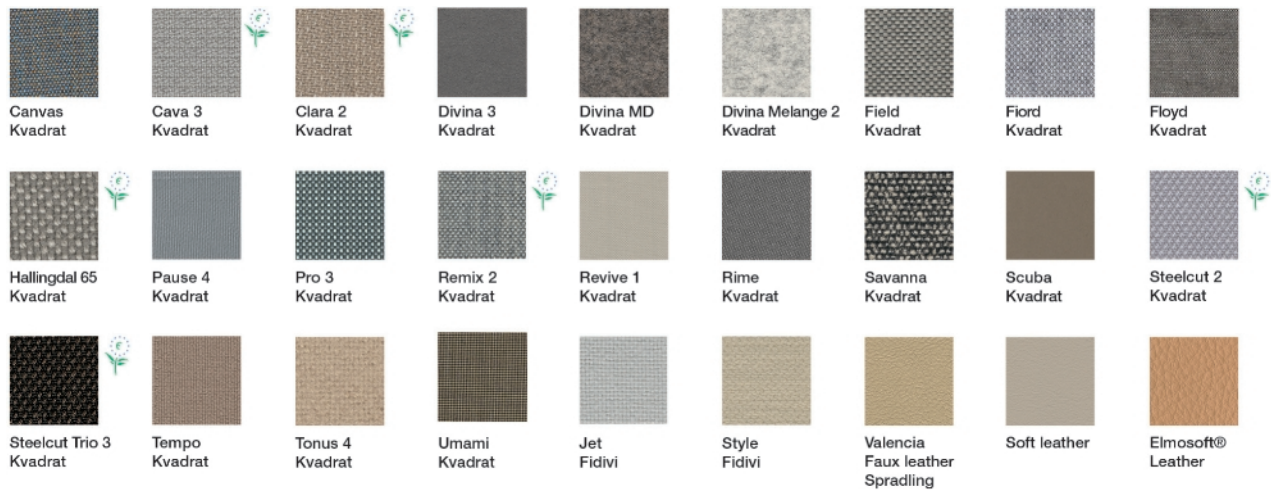

Graded In

kvadrat

camira



DESIGN
TEX



Gabriel



svensson

maharam

Serge Ferrari

Duna 02

Design by Lievore Altherr Molina, 2014

SHIPMENT DETAILS

Art.4237

1 pz = 2  - kg 15,38/ m³ 0,37

4 pz = 2  - kg 46,6/ m³ 0,55

TECHNICAL SPECIFICATIONS

Art.4237

COL requirement m² 2.66

H 140 cm. COM Meterage ml 1.72

RESISTANCE TEST

- EN 1728:2012 - EN 16139:2013 6.10
- EN 1728:2012 - EN 16139:2013 6.17
- EN 1728:2012 - EN 16139:2013 6.20
- EN 1728:2012 - EN 16139:2013 6.25
- EN 1728:2012 - EN 16139:2013 6. 4
- EN 1022:05

- EN 1728:2012 - EN 16139:2013 6.11
- EN 1728:2012 - EN 16139:2013 6.18
- EN 1728:2012 - EN 16139:2013 6.24
- EN 1728:2012 - EN 16139:2013 6.26
- EN 1728:2012 - EN 16139:2013 6. 5

FIRE RETARDANT TEST

ENVIRONMENTAL CERTIFICATIONS



arper

F +39 0422 791800

T +39 0422 7918

www.arper.com